

EXPLODED VIEW

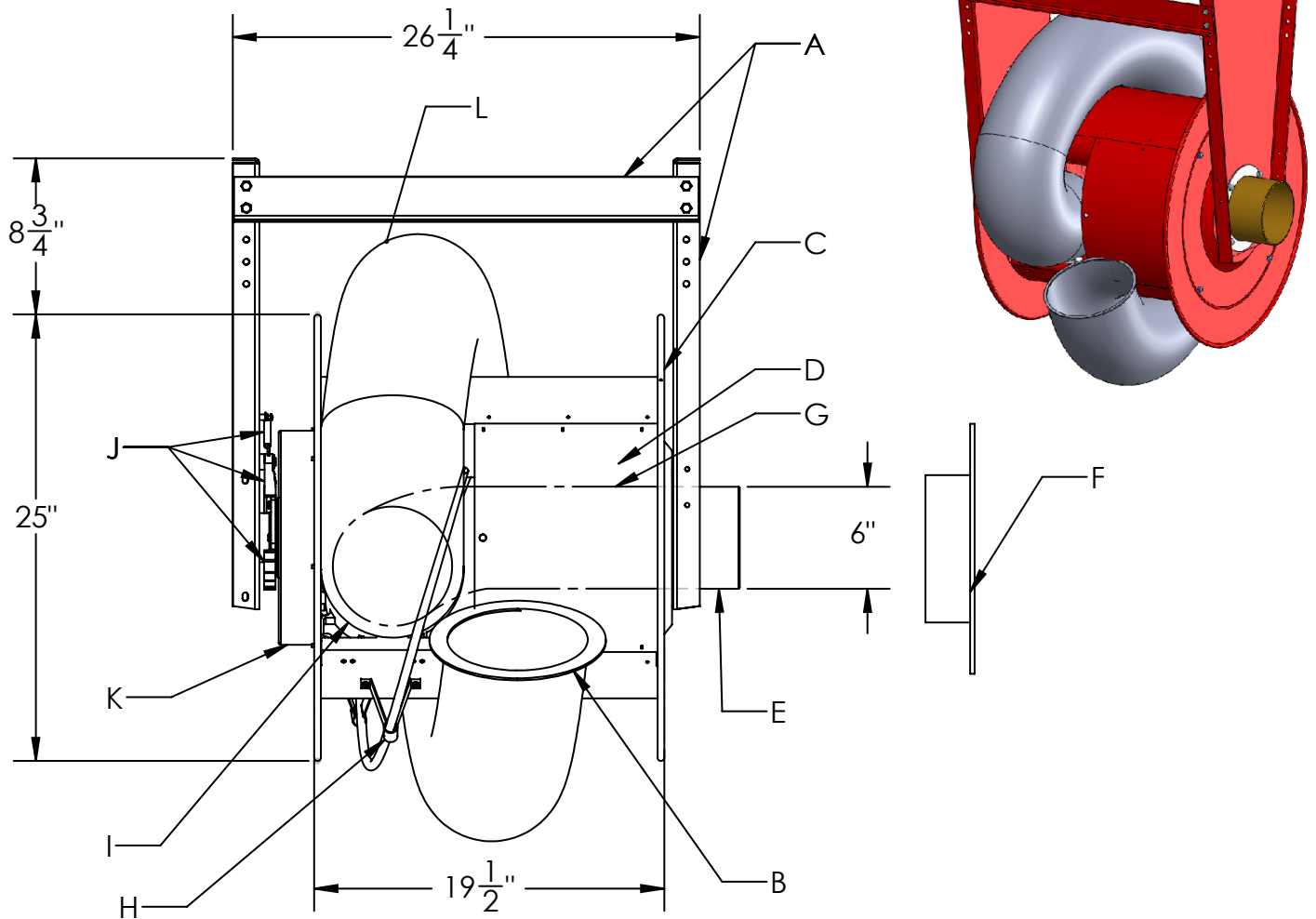

- A - Heavy Gauge Steel Support Mounting Frame
- B - Adjustable Hose Stop
- C - End Flanges
- D - Drum Assembly - 18" Diameter
- E - Duct Connection Fitting & Bearing Assembly
- F - Optional Mounting Flange for Direct Mount Fan
- G - Internal Hose Tube - 6" Diameter
- H - Hose Tracking Bar
- I - Hose to Drum Connector - 4", 5", 6" Diameter
- J - Lock and Latch Mechanism
- K - Spring Cassette Unit
- L - Extraction Hose - 4", 5", 6" Diameter

<u>Model</u>	<u>Hose Dia.</u>	<u>Max. Hose Capacity on Drum</u>	<u>Drum Diameter</u>	<u>Drum Width</u>
9000	4"	25'	18"	19"
9000	5"	20'	18"	19"
9000	6"	20'	18"	19"