

EXPLODED VIEW

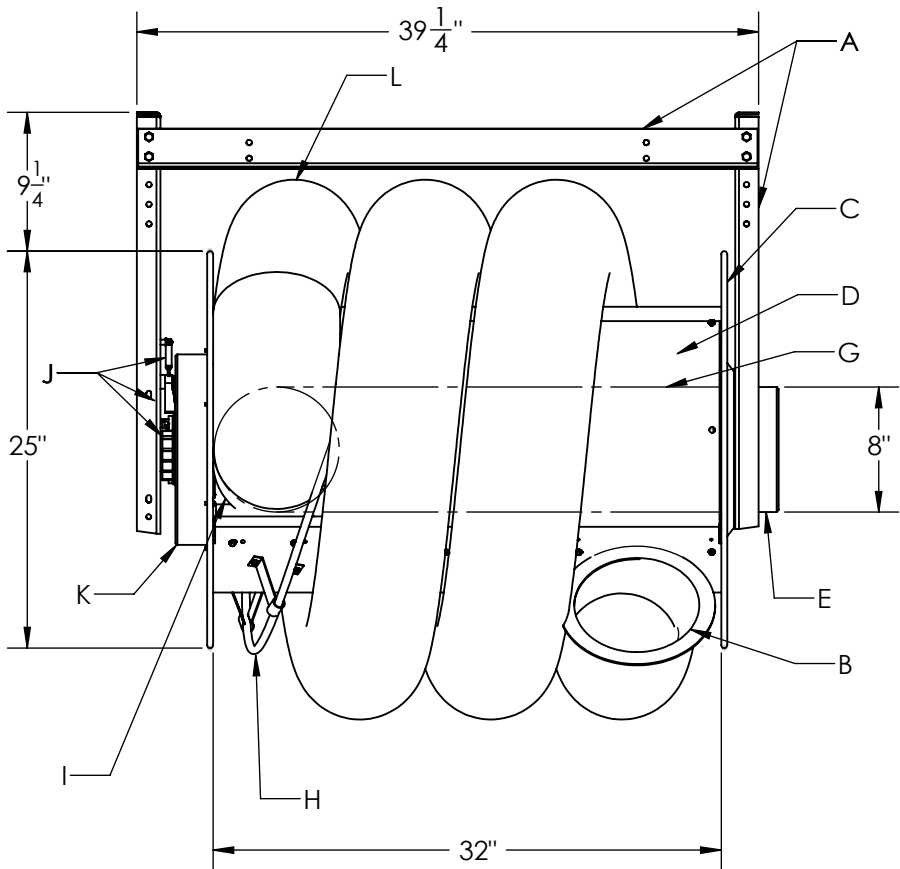

NOTE: The above dimensions are the same for both the motor operated hose reel and the widened version of the spring retractable hose reel (Series 9000-W).

- | | |
|---------------------------------------------------|------------------------------------------|
| A - Heavy Gauge Steel Support Mounting Frame | G - Internal Hose Tube - 8" Diameter |
| B - Adjustable Hose Stop | H - Hose Tracking Bar |
| C - End Flanges | I - Hose to Drum Connector - 8" Diameter |
| D - Drum Assembly - 18" Diameter | J - Lock and Latch Mechanism |
| E - Duct Connection Fitting & Bearing Assembly | K - Spring Cassette Unit |
| F - Optional Mounting Flange for Direct Mount Fan | L - Extraction Hose - 8" Diameter |

<u>Model</u>	<u>Hose Dia.</u>	<u>Max. Hose Capacity on Drum</u>	<u>Drum Diameter</u>	<u>Drum Width</u>
9000-W	8"	24'	18"	32"