



Source Capture Extraction
15000-D, Vertical Duct
Mount Arm

**TECHNICAL
INFORMATION**

PROJECT: _____
LOCATION: _____
ARCHITECT: _____
ENGINEER: _____
SALES ENGINEER: _____
DATE: _____

www.monoxivent.com

info@monoxivent.com

309-794-1000

Page: WSC-9

EXPLODED VIEW of SERIES 15000-D VERTICAL DUCT MOUNT ARM

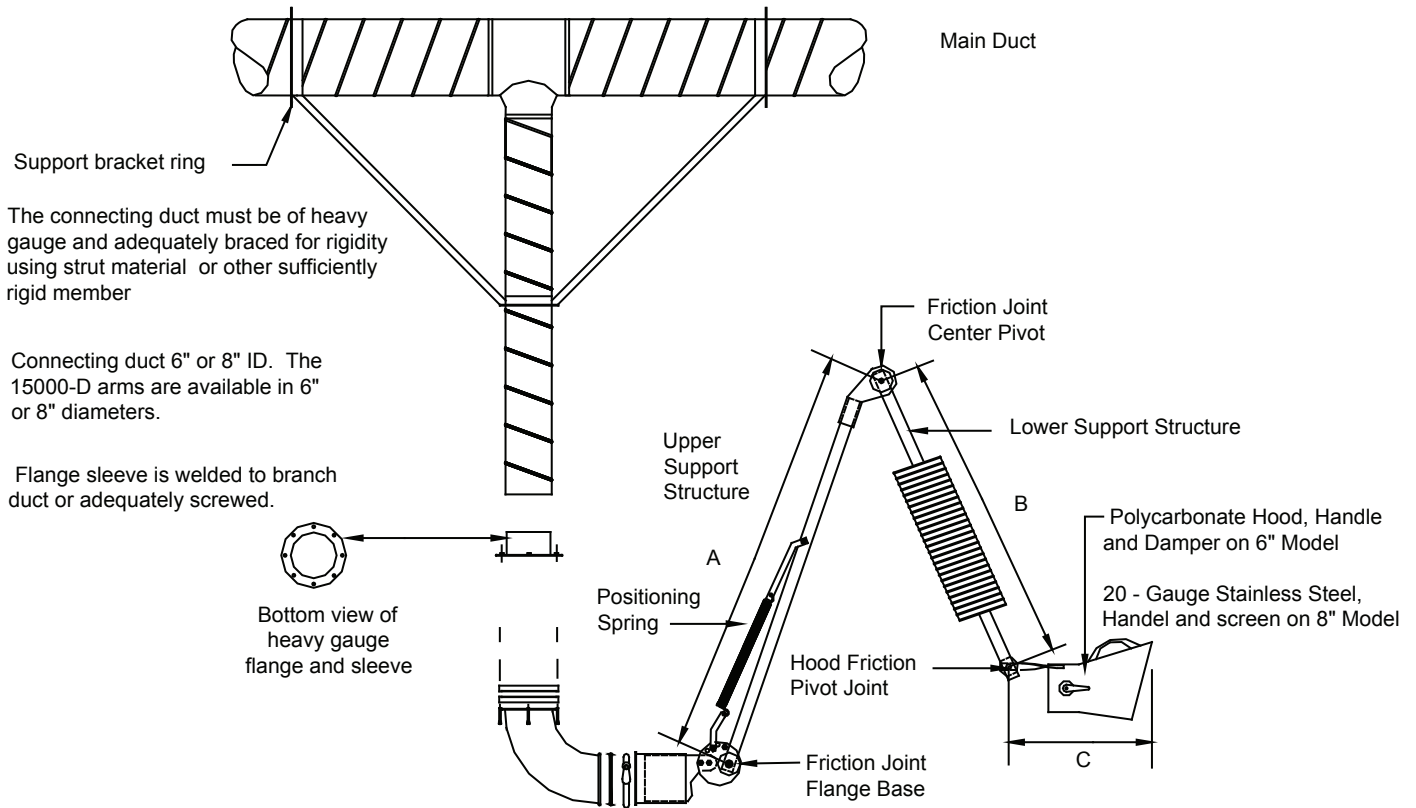

Model	Dimensions, Inches, 15000 Arms		
	A	B	C
15076-D, 15078-D	34"	22"	17"
15106-D, 15108-D	54"	42"	17"
15146-D, 15148-D	73"	61"	17"

Note: See other WSC pages for detail information for swivel collar, flanged swivel elbow, gasket and joint clamp.