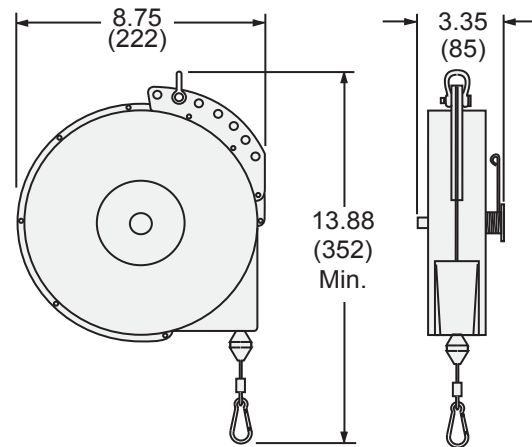

MODEL BAL-T

All Dimensions in INCHES (mm)

Standard Features of the BAL-T:

- A. Lock Mechanism to Permit Operator to Stop at Desired Position
- B. Slight Pull on Cable to Release Stop Lock
- C. An "off" Switch to Disengage the Lock Mechanism
- D. External Tension Adjustment Provides Fast and Easy Fine Tuning
- E. 15 Ft. of 3/32" Diameter Steel Cable and Adjustable Cable Stop
- F. Snap Hook, Multi-Directional Cable Guide, Forge Clevis Top Mount
- G. Automatic Safety Lock (spring fails then drum automatically locks)
- H. Safety Chain
- I. Maintenance Free and is Lifetime Lubricated at Factory
- J. Lifting Capacity of 15 Pounds

* For further details please refer to manual and parts list.