



Belt Drive Backward
Incline Fans

SERIES BI - 135

**TECHNICAL
INFORMATION**

PROJECT: _____
 LOCATION: _____
 ARCHITECT: _____
 ENGINEER: _____
 SALES ENGINEER: _____
 DATE: _____

www.monoxivent.com

info@monoxivent.com

309-794-1000

Page: EF-17

Wheel Diameter - 13.5"
 Wheel Type - Flatblade
 Tip Speed (FPM) = 3.53 x RPM
 Max. BHP = .12 x (RPM/1000)³
 Inlet Area - 1.12 Sq. Ft.
 Outlet Area - 1.06 Sq. Ft.
 Outlet Velocity (FPM) = CFM/1.06
 Max. Mtr. Frame Size - 184T, Arr. 10
 Approx. Shipping Weight
 BI-135 - 255 lbs.

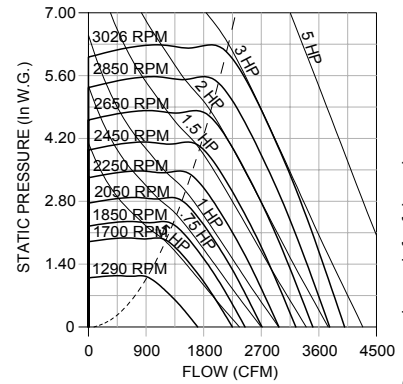
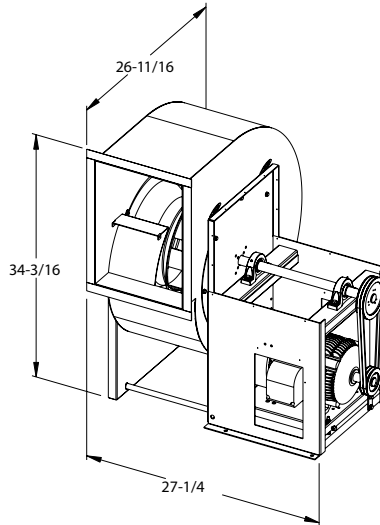

CFM	OV	1.000 SP		1.250 SP		1.500 SP		1.750 SP		2.000 SP		2.500 SP		3.000 SP		3.500 SP		4.000 SP		4.500 SP		5.000 SP	
		RPM	BHP	RPM	BHP	RPM	BHP	RPM	BHP	RPM	BHP	RPM	BHP	RPM	BHP	RPM	BHP	RPM	BHP	RPM	BHP	RPM	BHP
1050	994	1290	0.23	1392	0.29																		
1225	1159	1375	0.28	1466	0.34	1554	0.40	1640	0.46														
1400	1325	1467	0.34	1553	0.40	1634	0.47	1712	0.54	1788	0.61												
1575	1491	1565	0.41	1646	0.48	1722	0.55	1796	0.63	1867	0.70	2003	0.86	2138	1.03								
1750	1656	1667	0.49	1743	0.57	1816	0.65	1886	0.72	1953	0.80	2082	0.97	2205	1.14	2326	1.33						
1925	1822	1774	0.59	1845	0.67	1914	0.75	1981	0.84	2045	0.92	2168	1.10	2284	1.28	2397	1.47	2507	1.67	2617	1.88		
2100	1988	1885	0.70	1951	0.79	2016	0.88	2079	0.97	2141	1.06	2259	1.24	2370	1.44	2477	1.64	2581	1.84	2682	2.06	2783	2.28
2275	2153	1998	0.83	2061	0.92	2121	1.01	2182	1.11	2240	1.21	2354	1.41	2461	1.61	2564	1.82	2663	2.03	2759	2.26	2853	2.48
2450	2319	2114	0.97	2172	1.07	2231	1.17	2287	1.27	2343	1.37	2451	1.58	2555	1.80	2655	2.02	2750	2.25	2842	2.47	2932	2.71
2625	2485	2231	1.13	2287	1.23	2342	1.34	2396	1.45	2448	1.56	2552	1.78	2652	2.01	2748	2.24	2841	2.48	2930	2.72	3017	2.96
2800	2650	2351	1.30	2403	1.42	2456	1.53	2507	1.65	2557	1.76	2656	2.00	2752	2.24	2845	2.48	2934	2.73	3022	2.98		
2975	2816	2470	1.50	2522	1.62	2572	1.74	2621	1.87	2668	1.99	2763	2.24	2854	2.49	2944	2.74						
3150	2982	2593	1.72	2641	1.85	2689	1.98	2735	2.10	2781	2.23	2872	2.50	2959	2.76								
3325	3147	2715	1.95	2761	2.09	2807	2.23	2852	2.37	2896	2.50	2983	2.78										
3500	3313	2839	2.22	2884	2.36	2928	2.51	2971	2.65	3013	2.80												
3675	3479	2962	2.50	3005	2.65																		