

XL Series Hose Reels - Oversized • 24" Drum Diameter - 3' Drum Width (XL-24-3)

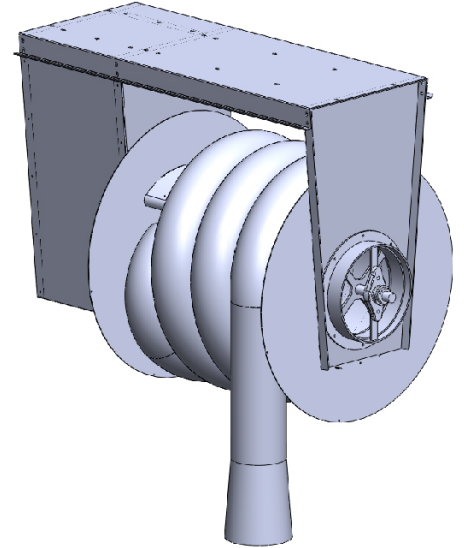
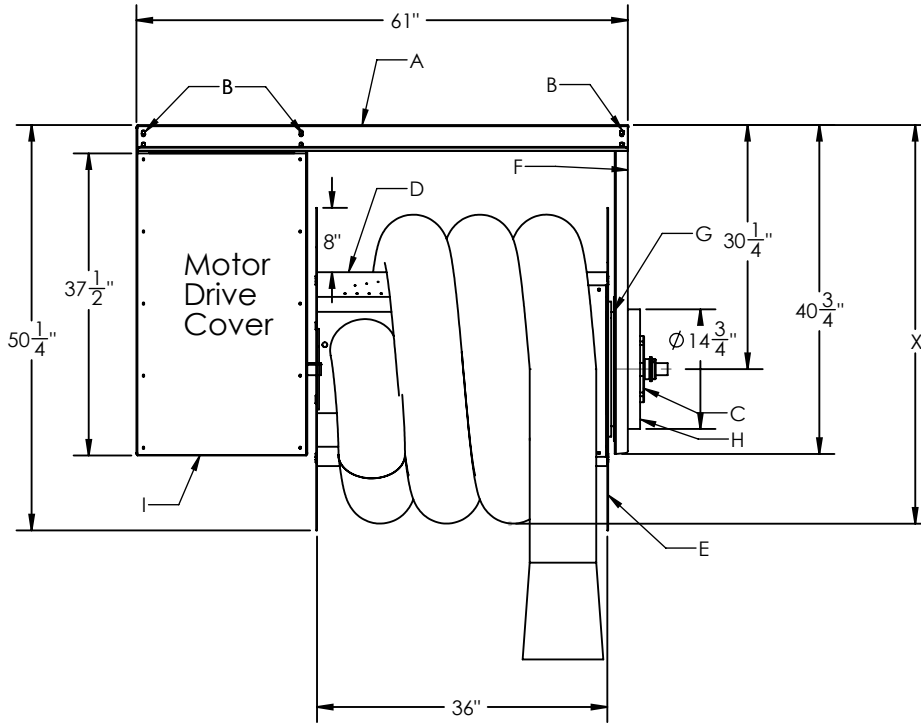

- ID:
A. Support Frame
B. 7/16" Mounting Holes, through A-Frame and Base Plate (Location for Hanger Channels)
C. Bearings
D. 16-Gauge Drum
E. 12-Gauge Drum Ends
F. 10-Gauge End Frame
G. Interior outlet bearing sleeve
H. Inner, Outer Ring Outlet
I. 18-Gauge Motor Cover

"X" Dimension (Nominal ID), with Hose on Reel:

- 8" diameter hose = 51"
10" diameter hose = 53"
12" diameter hose = 55"

* Note #1: The outside dimension, for the Nominal Hose ID, may vary - please consult factory.

* Note #2: Nominal dimensions, without allowances for materials to hang and support hose reels.

NOTES:

- * XL-24-3: Weight - 620 lbs.
- * Operator - Standard: 1/2 HP 115/230/1 or Optional: 1/2 HP 230/460/3 Chain Driven ODP Motor Assembly, 2-button Up/Down Switch, and Internal Automatic Reset Thermal Overload
- * Optional: Explosion Proof Motor Drive with Push Button Control
- * Hose Reel shall be powder-coated Red (optional stainless steel construction)
- * Contact factory for flex hose options



24" DRUM WIDTH • CAPACITIES

Model	Drum Dia.	Drum W.	Hose Dia.	Hose Capacity
XL-24-3	24"	3'	8"	Up to 35'
	24"	3'	10"	Up to 30'
	24"	3'	12"	Up to 25'