

MNX-30SN90 with FT40E

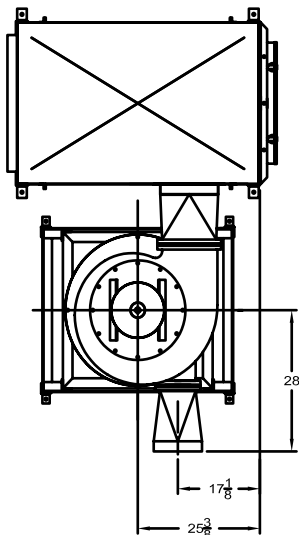
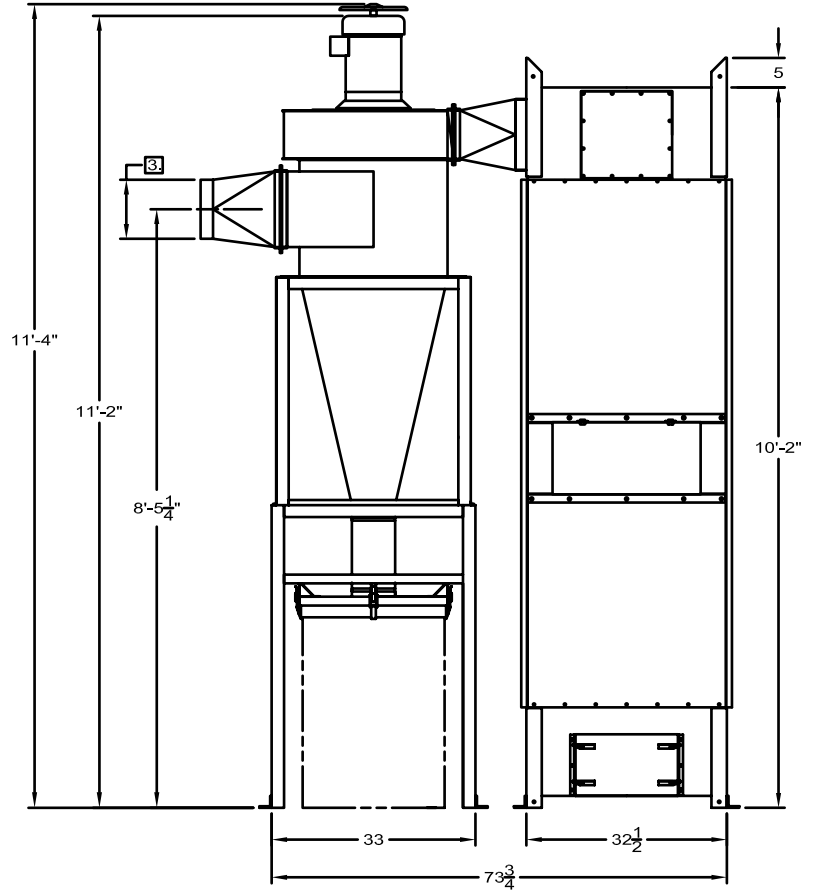
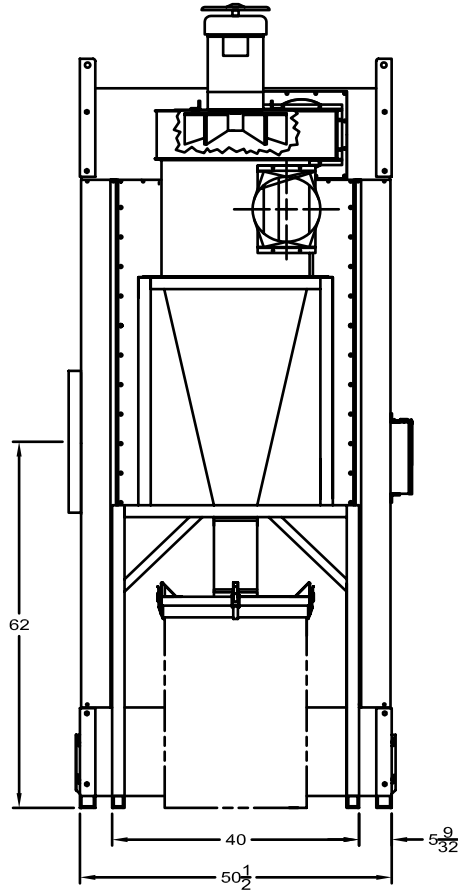

- 5. REFER TO INDIVIDUAL UNIT PRINTS FOR PARTS AND DETAILS
- 4. FILTER AREA - 375 SQ. FT.
- 3. OPTIONAL INLET SIZES - 10", 11", OR 12" I.D.
- 2. TOTAL DUST STORAGE CAPACITY - 7.3 CU. FT. CYCLONE, 14.8 CU. FT. FILTER
- 1. CUSTOMER TO SUPPLY ONE (1) 55 GALLON DRUMS FOR DUST STORAGE

■ **NOTE** ■