

# MNX-80SN70 with FT640

■ INLET VIEW ■

■ RIGHT SIDE VIEW ■

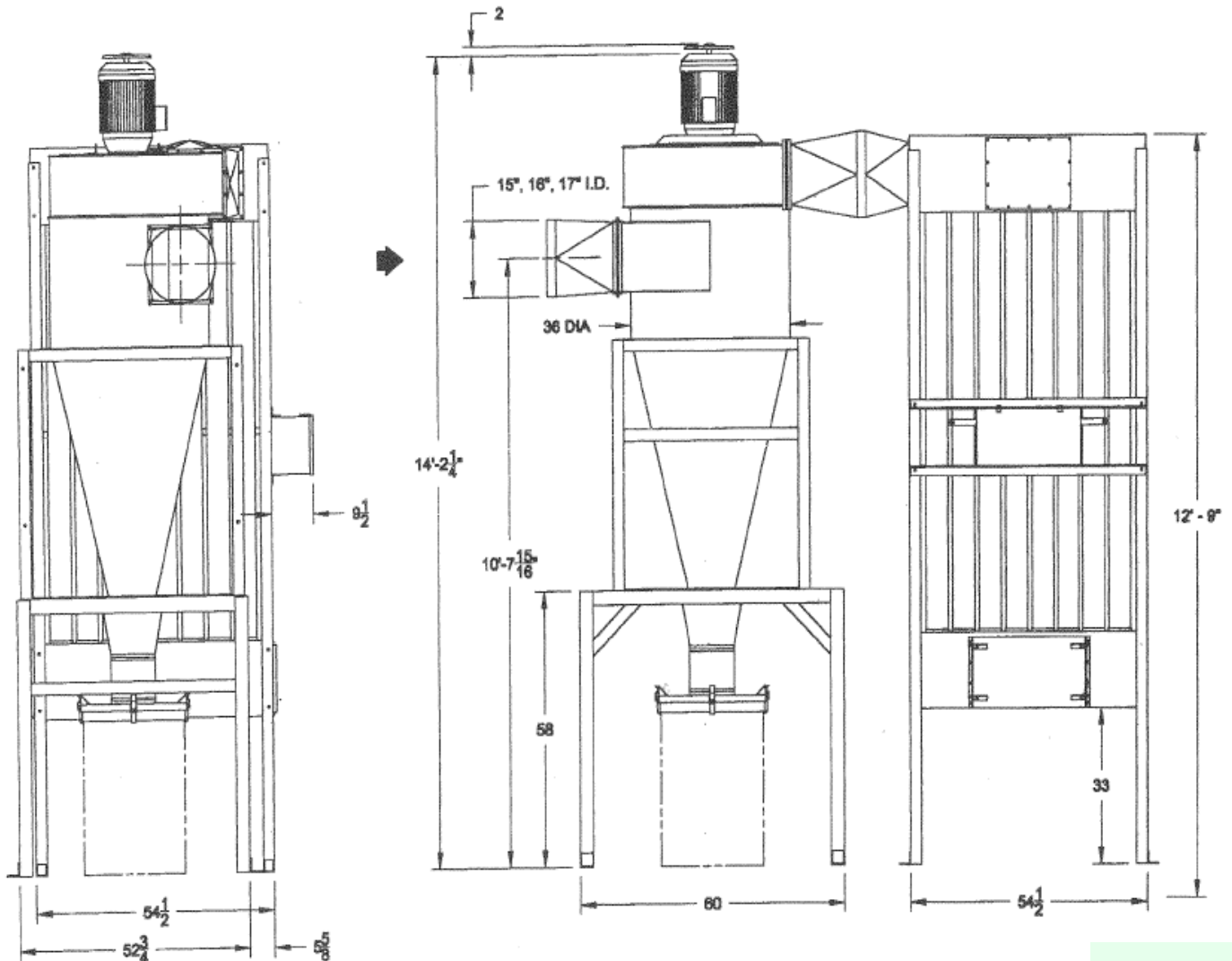

4. REFER TO INDIVIDUAL UNIT PRINTS FOR PARTS AND DETAILS
3. FILTER AREA - 812 SQ. FT.
2. DUST STORAGE CAPCITIES - 7.3 CU. FT. (CYCLONE) AND 25 CU. FT. (FILTER)
1. CUSTOMER TO SUPPLY ONE (1) 55 GALLON DRUM FOR DUST STORAGE (7.3 CU. FT. STORAGE CAPACITY)

■ NOTE ■