

MONOXIVENT®

Source Capture Systems

Operation and Maintenance Manual

D-Series Blowers and Exhausters



MONOXIVENT - SOURCE CAPTURE SYSTEMS

1306 Mill St., Rock Island, IL 61201
877-608-4383 - info@monoxivent.com
monoxivent.com

MONOXVENT BLOWERS AND EXHAUSTERS

| | |
|-------|---------------------------------------|
| D05-1 | ½ HP TEFC 115/230 VOLTS, 1 PH |
| D05-3 | ½ HP TEFC 208/230/460 VOLTS, 3 PH |
| D10-1 | 1 HP TEFC 115/230 VOLTS, 1 PH |
| D10-3 | 1 HP TEFC 208/230/460 VOLTS, 3 PH |
| D15-1 | 1-1/2 HP TEFC 115/230 VOLTS, 1 PH |
| D15-3 | 1-1/2 HP TEFC 208/230/460 VOLTS, 3 PH |
| D20-1 | 2 HP TEFC 115/230 VOLTS, 1 PH |
| D20-3 | 2 HP TEFC 208/230/460 VOLTS, 3 PH |
| D30-1 | 3 HP TEFC 115/230 VOLTS, 1 PH |
| D30-3 | 3 HP TEFC 208/230/460 VOLTS, 3 PH |

WARNING

Rotating equipment must be properly guarded to prevent personal injury.

By acceptance of the merchandise, the purchaser and user assumes complete responsibility for the safe operation of this equipment. The manufacturer disclaims any and all responsibilities unless this unit is operated in compliance with all federal and local laws and regulations.

I. Receiving Inspection

When unit is received, inspect immediately for damage. See the enclosed information sheet for reporting freight damaged equipment.

NOTE: This unit was inspected at the factory, any damage that occurred while in transit is the responsibility of the freight company.

The unit will arrive in one box holding blower-exhauster. Carefully remove all parts from the box and check items with parts list. Missing parts must be reported to Monoxivent within 15 working days after date of receipt.

NOTE: AFTER 15 WORKING DAYS HAVE PASSED, THE ORDER IS CONSIDERED COMPLETE.

II. ASSEMBLY

The tools necessary to complete assembly of the blower-exhauster are a screw driver and a wrench. See motor name plate for wiring diagram.

WIRING

1. **Have a qualified electrician wire the motor following the wiring diagram located on the motor nameplate for high or low voltage as needed.** Check nameplate for electric characteristics to connect motor to an identical power outlet. **(NOTE: Wiring directions do not guarantee proper rotation.)**

CAUTION: PROPER ROTATION IS ESSENTIAL TO ACHIEVE OPTIMUM CFM DELIVERY.

2. Before starting the unit, check the blower wheel to see that is rotating freely and that there are no obstructions or loose material present. If the unit has been in storage or subject to adverse moisture conditions, it is advisable to make sure the motor is dry before starting the unit.

CAUTION: BEFORE ELECTRICIAN LEAVES, VISUALLY CHECK ROTATION OF THE FAN WHEEL.

3. To check for proper rotation, turn the power ON and OFF quickly. As the blower is slowing down, check to see that the fan wheel is rotating in the same direction as the directional arrow located on the motor. If the fan is not turning in the direction of the rotation arrow, the unit is wired in reverse. There will be very little suction or air movement if wired in reverse. If the unit is wired correctly, the wheel should turn clockwise or toward the viewer. The proper rotation will increase the amount of suction by almost 50%. Follow instruction on motor wiring tag. **Note: D-series blowers do require reverse rotational wiring.**
4. If motor top is not vented (as with explosion proof motors) and view is obstructed, observe the blower wheel rotation by looking into the exhaust duct. The wheel should turn clockwise or toward the viewer if the unit is correctly wired.

CAUTION: DO NOT LOOK DIRECTLY INTO THE MOTOR COMPARTMENT OR OUTLET WITH THE POWER ON OR WITHOUT WEARING SAFETY GOGGLES.

III. MAINTENANCE AND SERVICE

Before any maintenance or service is performed, be sure that the unit is disconnected from the power source to prevent accidental starting.

A. BLOWER MAINTENANCE

Depending upon the intended application, the blower housing and fan wheel may be constructed of either steel or cast aluminum.

If the blower housing and fan wheel are constructed of steel, periodic cleaning may be necessary. In a severely dirty operation, the blower's impellers should be carefully cleaned with a wire brush to prevent any accumulation of foreign matter that could result in wheel imbalance. After cleaning impellers, inspect for any possible cracks or excessive wear which may cause imbalance and vibration. All sheet metal fittings are maintenance free and should not require any maintenance during the life of the unit.

If the blower housing and fan wheel are constructed of cast aluminum, they are maintenance free and should not require any maintenance during the life of the unit.

E. MOTOR MAINTENANCE

1. DUST AND DIRT

Blow off the motor using low pressure air to remove dust or dirt. Air pressure above 35 PSI should not be used because high pressure may damage insulation and blow dirt under the loosened tape. Dust may cause excessive insulation temperatures.

2. LUBRICATION

Lubrication of the motor should be done periodically as specified by the motor manufacturer. If the motor is run at continuous high ambiances, in dirty or moist locations, subject to high vibrations or where the shaft end is hot (pumps and fans), it is suggested that the motor should be lubricated approximately every 6 months. If the motor is equipped with Alemite fitting, clean the tip of the fitting and apply a grease gun containing Shell Alvania #2 Lithium Based Grease string into each hole in the motor.

On motors with drain plugs, remove grease drain plug, and operate motor for 20 minutes before replacing drain plug.

IV TROUBLE SHOOTING

A. MOTOR

1. DOES NOT START OR RUNS VERY SLOWLY

Check the wiring as the motor is probably wired incorrectly. **D-series blowers require reverse rotation wiring.** Have the electrician follow the wiring diagram on the motor nameplate. If the unit does not start or runs slowly, check all the wire connections for a bad connection. Repair if necessary. If the unit does not start or runs slowly, there is an internal motor problem, which must be handled by an authorized Baldor Service Center. Baldor service centers can be found at <http://www.baldor.com/resources-and-support/customer-support/service-centers>

2. NOISE

If the motor has unusual noises, check the cooling fan on top of the motor under the end bell. If the fan is broken form shipping, notify the freight line and the fan supplier. The fan must be replaced. If the cooling fan is intact and noises continue, call the supplier for directions.

3. SMOKE

If the motor is emitting smoke, check the voltage to make sure unit voltage and source voltage are the same. IF the motor has been damaged, repair must be done by an authorized Baldor Service Center. If the motor has been damaged by incorrect wiring by the customer or customer's representative, the motor's warranty has been made null and void. You may take the motor to any service center.

B. UNIT NOISE OTHER THAN MOTOR

Check to see that the wheel turns freely. With the unit disconnected from the electrical supply, rotate the wheel by hand. If the wheel is not turning freely, the wheel has slipped on the motor shaft. Determine if the wheel has slipped toward the motor or away from the motor. Through the intake opening, slightly loosen the 2 set screws. Put "Loctite" on the exposed threads of the screws. Move the wheel so that the motor side of the wheel is 3/16" from the housing. Tighten the screws and energize the motor. If the noise is still present, contact the supplier.

C. LITTLE SUCTION OR AIR MOVEMENT IMMEDIATELY AFTER START-UP

1. Motor is wired in reverse so that the blower wheel is turning backwards. Have the electrician wire the motor according to the wiring diagram located on the nameplate. If wheel still turns backwards, change the leads. If there are still problems, contact the supplier. **D-series blowers require reverse rotation wiring.**
2. Check for packaging or other material present on the inlet or outlet sides of the blower. If any material is present, remove before further operation of the unit.

D. REDUCED SUCTION AFTER RUNNING FOR A PERIOD OF TIME

1. Check for packaging or other material present on the inlet and outlet sides of the blower. Remove obstructions before further unit operation.
2. Check to see if intake hose or duct has been kinked, crushed or clogged, remove the obstructing matter.

E. NOT ENOUGH SUCTION TO EXHAUST POLLUTANT

1. If a nozzle is used, check the nozzle positioning. For the most efficient pickup, the nozzle should be 1 duct diameter or less from the source of pollutant. The nozzle must be located less than 2 times the duct diameter from the source of pollutant.

EXAMPLE: If hose or metal duct diameter is 6", then the nozzle should be 6" or less from the source of pollutant. To achieve adequate pickup, the nozzle must not be located more than 12" from the source of pollutant.

2. Check the length of the duct or hose and the number of bends in such. Excessive duct, hose lengths, or bends in such, will result in poor pick-up. Call the supplier if you have questions regarding your layout.
3. Check for the number of drops from the unit. The unit purchased may not have the correct specifications for the job. Contact the supplier if you have questions concerning the unit suitability.

LIMITED WARRANTY

1. The manufacturer warrants products of its own manufacturer against material and workmanship under normal use and service for a period of twelve (12) months from the date of shipment. This warranty does not cover ordinary wear and tear, overloading, abuse, altered products, systems or materials not of the seller's manufacturer. Expenses incurred by buyer(s) in repairing or replacing any defective product or part will not be allowed except where authorized in writing and signed by an officer of the seller.
2. The obligation of seller under this warranty shall be limited to repairing or replacing F.O.B. seller's plant, or allowing credit at seller's option.
3. On equipment furnished by seller, but manufactured by others, such as motors and/or electrical controls, seller extends the same warranty as seller receives from the manufacturer thereof.
4. The manufacturer assumes no responsibility for material returned to the plant, except where authorized in writing and signed by an officer of the manufacturer.

MONOXIVENT BLOWERS AND EXHAUSTERS PARTS
LIST

| PART # | QUANTITY | DESCRIPTION |
|--------|----------|--|
| | | (For D05-1) 1/2 HP TEFC 115/220 Volt, 1 PH, 3450 RPM, 56C |
| | | (For D05-3) 1/2 HP TEFC 208/230/460 Volts, 3 PH, 3450 RPM 56C |
| | | (For D10-1) 1 HP TEFC 115/230 Volts, 1 PH, 3450 RPM, 56C |
| | | (For D10-3) 1 HP TEFC 280/230/460 Volts, 3 PH, 3450 RPM, 56C |
| | | (For D15-1) 1-1/2 HP TEFC 115/230 Volts, 1 PH, 3450 RPM, 56C |
| | | (For D15-3) 1-1/2 HP TEFC 208/230/460 Volts, 3 PH, 3450 RPM, 56C |
| | | (For D20-1) 2 HP TEFC 115/220 Volt, 1 PH, 3450 RPM, 56C |
| | | (For D20-3) 2 HP TEFC 208/230/460 Volts, 3 PH, 3450 RPM, 56C |
| | | (For D30-1) 3 HP TEFC 115/220 Volt, 1 PH, 3450 RPM, 145 T |
| | | (For D30-3) 3 HP TEFC 208/230/460 Volts, 3 PH, 3450 RPM, 145 T |

SERIES D BLOWER MOTOR CHECK LIST:

- A. Check wheel rotation by using the cooling fan compared to the black arrow on the fan housing.
- B. Check motor tag and confirm motor horse power, voltage, and phase.
- C. Note that motor tag has wiring diagram for low and high voltages. D-series blowers require reverse rotation wiring.
- D. Confirm motor wiring from power source to the motor. Check wire gauge as related to voltage, phase, and the distance the wire is being run.
- E. Check for proper starter components as related to overload protection, transformers, and confirm for proper and correct wiring of the starter components.
- F. Check that the starter components are good and in proper operating condition. Check for any loose connections.
- G. Check for any loose wires throughout the entire electrical system.
- H. Check all connections with proper electrician's meters for any faults. Amp draw, voltage reading etc.
- I. Take readings at the motor of the blower to ensure correct amps and voltages based upon motor tag specifications.

THE SERIES D BLOWER IS A HIGH QUALITY PRESSURE STYLE UNIT. THE CONSTRUCTION IS OF FORGED CAST ALUMINUM FOR BOTH THE HOUSING AND THE WHEEL. THE MOTOR IS A TEFC AND IS BOTH UL & CSA APPROVED.

THE SERIES D BLOWER IS MADE IN THE USA.

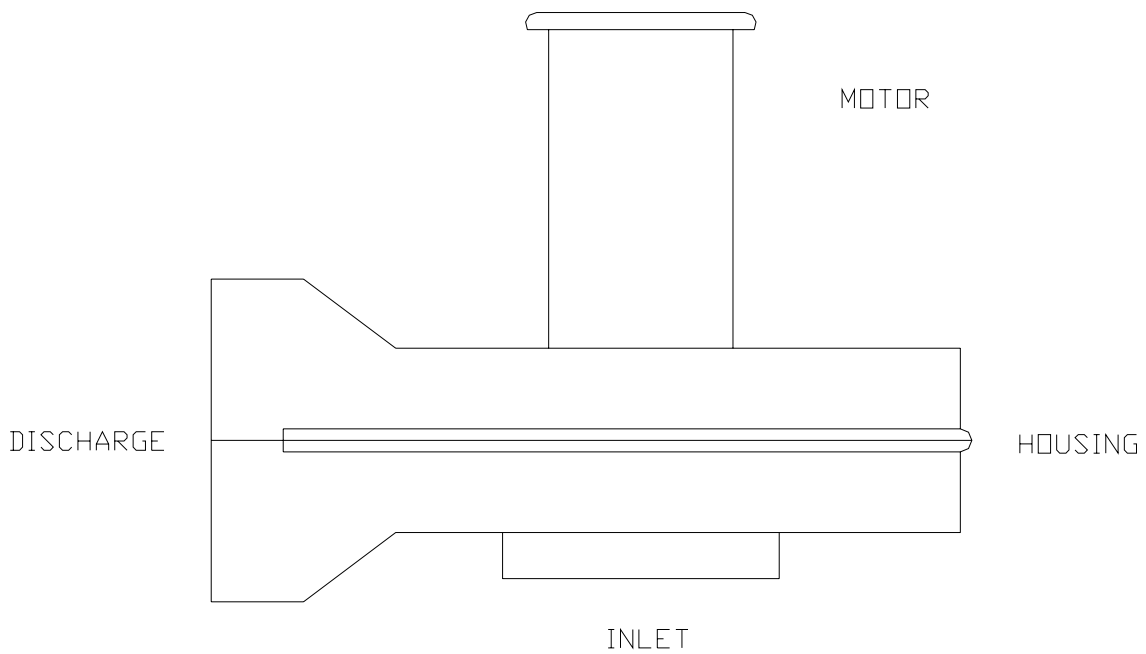

HOUSING AND WHEELS ARE AVAILABLE LESS MOTORS.

SOUNDING RATING ESTIMATION BASED UPON 5' DISCHARGE DUCT AND RATING
TAKING ON THE FAN DISCHARGE 80-85 dba.

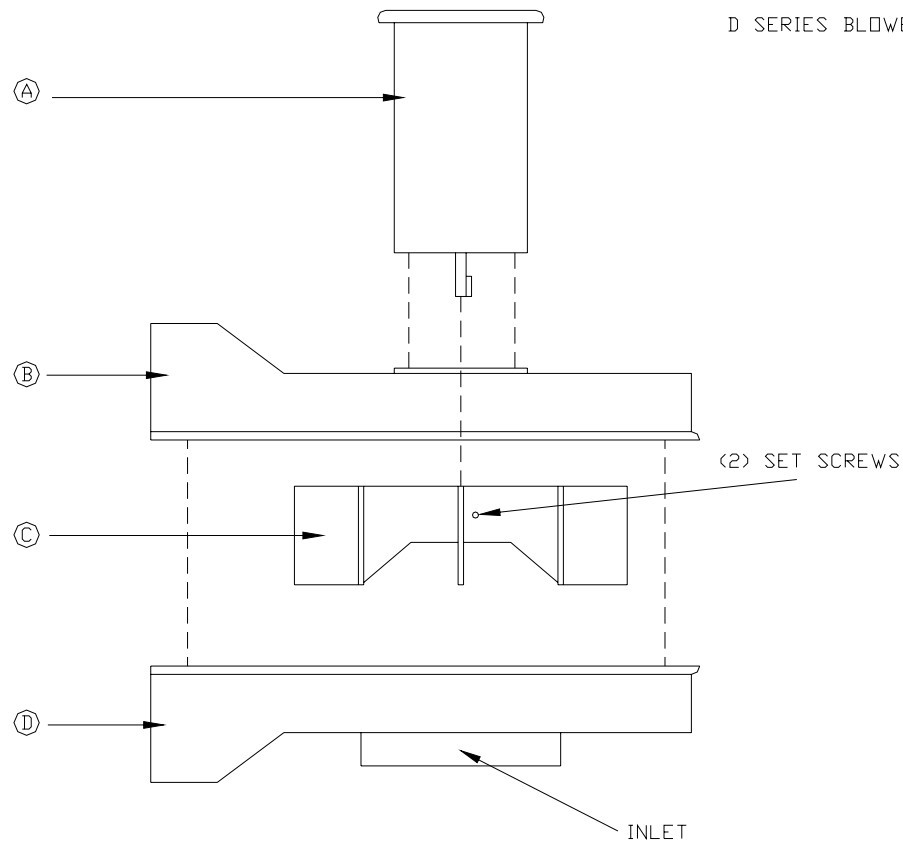

- A UL/CSA APPROVED TEFC MOTOR – 3450 RPM
- B TOP HOUSING CONSTRUCTED OF ALL ALUMINUM
- C RADIAL WHEEL CONSTRUCTED OF ALL ALUMINUM
- D BOTTOM HOUSING CONSTRUCTED OF ALL ALUMINUM

THE D SERIES BLOWER IS A VERSATILE EXHAUSTER CONSTRUCTED OF ALL ALUMINUM. THE BLOWER IS AVAILABLE IN SEVERAL COMBINATIONS:

| | | |
|-----|--------|---------------------------------------|
| D05 | ½ HP | USING A 10-5/8" WHEEL (SMALL HOUSING) |
| D10 | 1 HP | USING A 11-1/2" WHEEL (LARGE HOUSING) |
| D15 | 1 ½ HP | USING A 11-1/2" WHEEL (LARGE HOUSING) |
| D20 | 2 HP | USING A 13-3/8" WHEEL (LARGE HOUSING) |
| D30 | 3 HP | USING A 13-3/8" WHEEL (LARGE HOUSING) |

THE D SERIES BLOWER CAN BE SUPPLIED WITH OR WITHOUT MOUNTING BRACKET. ABOVE BLOWER IS SHOWING MOTOR, HOUSING, AND WHEEL ONLY.

HOUSING AND WHEELS ARE AVAILABLE LESS MOTORS.

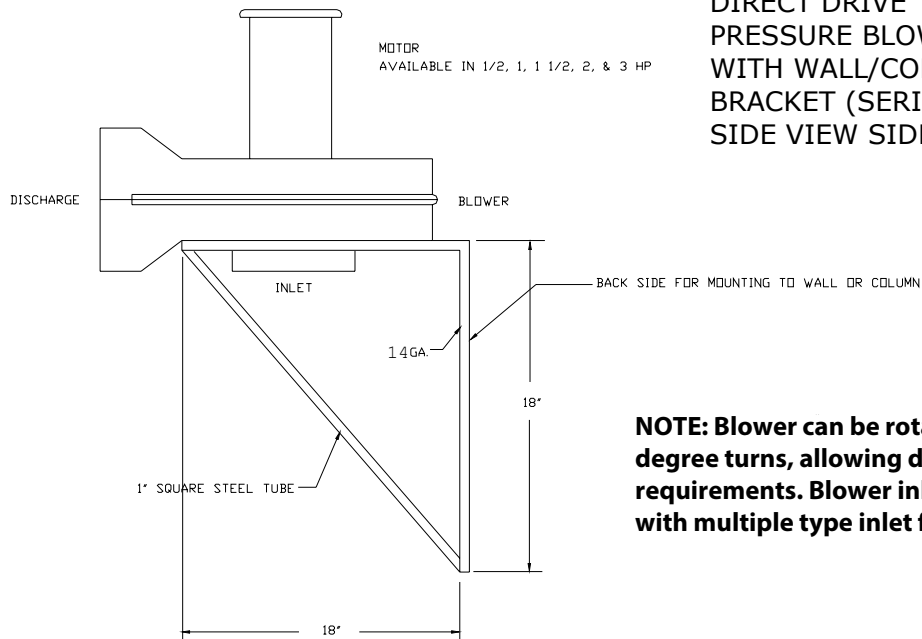

MONOXIVENT
DIRECT DRIVE
PRESSURE BLOWER
WITH WALL/COLUMN
BRACKET (SERIES D)
SIDE VIEW SIDE VIEW

NOTE: Blower can be rotated in circle at 90 degree turns, allowing discharge to meet requirements. Blower inlet can be supplied with multiple type inlet fittings.

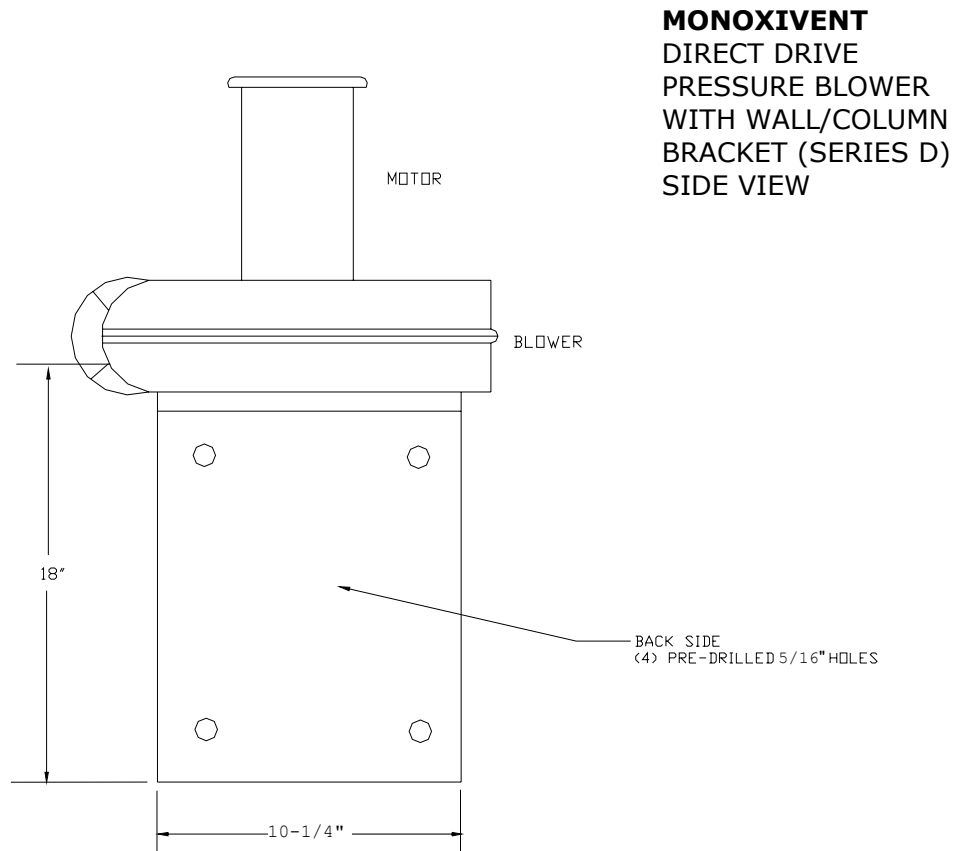

MONOXIVENT
DIRECT DRIVE
PRESSURE BLOWER
WITH WALL/COLUMN
BRACKET (SERIES D)
SIDE VIEW

NOTE: DIRECT MOUNT FANS ARE AN OPTION

Side View

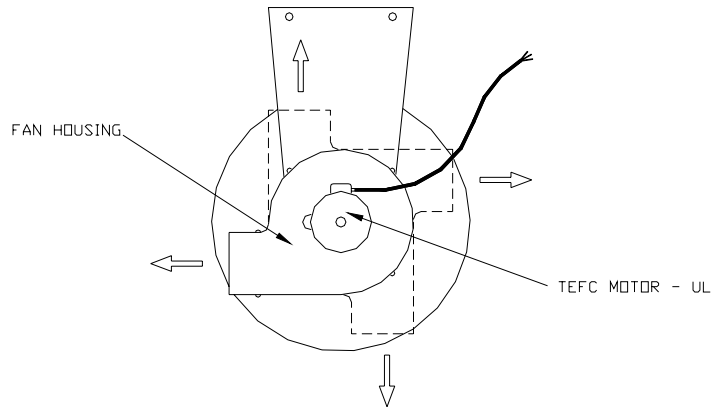

SYSTEM IS SUPPLIED WITH MULTIPLE POSITION FAN DISCHARGE



Front View

